

**AS SURVEYED BOUNDARY DESCRIPTION**

A PART OF THE SOUTHEAST QUARTER OF SECTION 28, TOWNSHIP 7 NORTH, RANGE 1 WEST OF THE SALT LAKE BASE AND MERIDIAN.

BEGINNING AT THE NORTHWEST CORNER OF THE LEWIS & GAY BARKER FAMILY TRUST PROPERTY, TAX ID. NO. 17-018-0028, POINT ALSO BEING ON THE EASTERLY RIGHT-OF-WAY LINE OF 850 EAST STREET LOCATED 1547.24 FEET NORTH 89°02'17" WEST ALONG THE SOUTH LINE OF SAID SECTION 28 AND 752.69 FEET NORTH 00°57'43" EAST FROM THE SOUTHEAST CORNER OF SAID SECTION 28;

RUNNING THENCE NORTH 14°58'50" EAST 95.19 FEET ALONG SAID EASTERLY RIGHT-OF-WAY LINE TO THE SOUTHWEST CORNER OF THE RICKY & KARLA HAWKS PROPERTY, TAX ID. NO. 17-018-0009; THENCE SOUTH 82°59'29" EAST 275.37 FEET ALONG THE SOUTH LINE OF SAID RICKY & KARLA HAWKS PROPERTY TO THE WEST LINE OF RICE CREEK COVE, ENTRY NO. 2844736; THENCE SOUTH 04°44'54" WEST 94.34 FEET ALONG THE WEST LINE OF SAID RICE CREEK COVE TO THE NORTHEAST CORNER OF SAID LEWIS & GAY BARKER FAMILY TRUST PROPERTY; THENCE NORTH 82°59'28" WEST 292.29 FEET ALONG THE NORTH LINE OF SAID LEWIS & GAY BARKER FAMILY TRUST PROPERTY TO THE POINT OF BEGINNING. CONTAINING 0.61 ACRES.

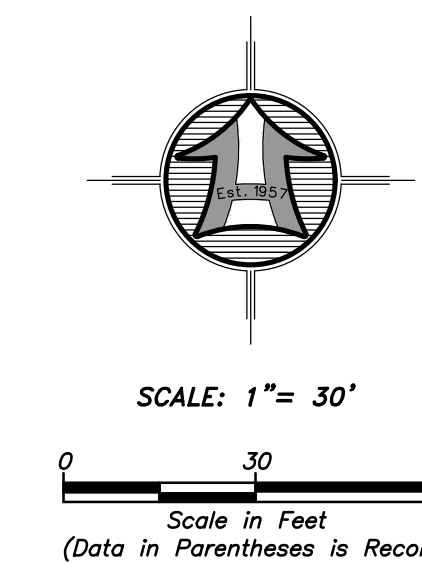

**LEGEND**

	SUBJECT PROPERTY LINE
	ADJOINING PROPERTY LINE
	PREVIOUS PROPERTY LINE
	CENTERLINE
	FENCE LINE
	FOUND REBAR SET BY OTHERS
	SET 5/8"x24" REBAR WITH CAP SECTION CORNER

**RICE CREEK COVE**  
(ENTRY NO. 2844736)

**NARRATIVE**

THE PURPOSE OF THIS SURVEY WAS TO ESTABLISH AND SET THE PROPERTY CORNERS OF THE PARCEL AS SHOWN AND DESCRIBED HEREON. THE SURVEY WAS ORDERED BY BLAKE EARL. THE CONTROL USED TO ESTABLISH THE PROPERTY CORNERS WAS ROS NO. 6538 AND THE EXISTING BOX ELDER COUNTY SURVEY MONUMENTATION SURROUNDING SECTION 28, T7N, R1W, SLB&M.

THE BASIS OF BEARING IS THE SOUTH LINE OF SAID SECTION WHICH BEARS NORTH 89°02'17" WEST, UTAH NORTH, STATE PLANE, CALCULATED N.A.D.83 BEARING.

**SURVEYOR'S CERTIFICATE**

I, MATT PRETL DO HEREBY CERTIFY THAT I AM A REGISTERED PROFESSIONAL LAND SURVEYOR IN THE STATE OF UTAH IN ACCORDANCE WITH TITLE 58, CHAPTER 22, PROFESSIONAL ENGINEERS AND PROFESSIONAL LAND SURVEYORS ACT; AND BY THE AUTHORITY OF THE OWNERS, I HAVE COMPLETED A SURVEY OF THE PROPERTY DESCRIBED AND SHOWN HEREON THIS PLAT IN ACCORDANCE WITH SECTION 17-23-17 AND HAVE VERIFIED ALL MEASUREMENTS, AND THAT THE SAME HAS BEEN SURVEYED AND MONUMENTS HAVE BEEN LOCATED AND/OR PLACED ON THE GROUND AS REPRESENTED ON THE PLAT HEREON.

SIGNED THIS 8TH DAY OF JANUARY, 2026.

MATT PRETL, PLS  
UTAH LAND SURVEYOR LICENSE NO. 10437995



SOUTHWEST CORNER OF SEC. 28,  
T. 7 N., R. 1 W., SLB&M  
FOUND WEBER CO. BRASS CAP  
MONUMENT

SOUTHWEST CORNER OF SEC. 28,  
T. 7 N., R. 1 W., SLB&M  
FOUND WEBER CO. BRASS CAP  
MONUMENT

**RECEIVED**  
FEB 20 2026  
FILE # 8287

**HANSEN & ASSOCIATES, INC.**  
Consulting Engineers and Land Surveyors  
538 North Main Street, Brigham, Utah 84302  
Visit us at [www.hales.net](http://www.hales.net)  
Brigham City, Ogden, Logan  
(435) 723-3491 (801) 399-4905 (435) 752-8272  
Since 1957

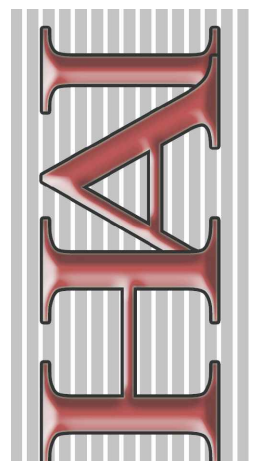

Drawn By: MP Date: 12/11/2025  
Designed By: \_\_\_\_\_  
Checked By: \_\_\_\_\_  
Approved By: \_\_\_\_\_  
Scale: 1" = 30'  
Drawing File: 25-3-289 BLAKE EARL  
JOB NUMBER: 25-3-289

PROPERTY SURVEY FOR  
**BLAKE EARL**  
2726 NORTH 850 EAST  
NORTH OGDEN, WEBER COUNTY, UTAH.  
A PART OF THE SOUTHEAST QUARTER OF SECTION 28  
TOWNSHIP 7 NORTH, RANGE 1 WEST, S.L.B.&M.