

AS SURVEYED BOUNDARY DESCRIPTION
 ALL OF LOT 2, 12TH STREET PLAZA SUBDIVISION, ENTRY NO. 1743446

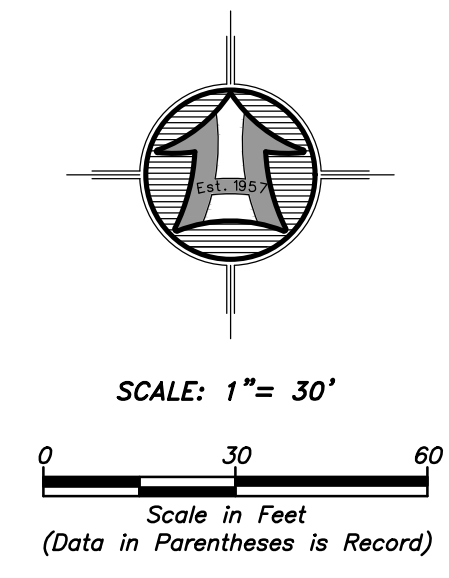

LEGEND

	SUBJECT PROPERTY LINE
	ADJOINING PROPERTY LINE
	PREVIOUS PROPERTY LINE
	CENTERLINE
	DITCH
	FIELD SEPARATION LINE
	FENCE LINE
	STREET MONUMENT
	FOUND REBAR SET BY OTHERS
	SET 5/8"x24" REBAR WITH CAP

RECEIVED
 FEB 20 2026
 FILE # 8285

NARRATIVE

THE PURPOSE OF THIS SURVEY WAS TO ESTABLISH AND SET THE PROPERTY CORNERS OF THE PARCEL AS SHOWN AND DESCRIBED HEREON. THE SURVEY WAS ORDERED BY BRIAN BARTHOLOMEW FOR FROG PROPERTIES. THE CONTROL USED TO ESTABLISH THE PROPERTY CORNERS WAS THE 12TH STREET PLAZA CONDOMINIUMS PLAT, ENTRY NO. 1745680, 12TH STREET PLAZA SUBDIVISION, ENTRY NO. 1743446, OGDEN CITY MONUMENTS, AND THE EXISTING WEBER COUNTY SURVEY MONUMENTATION SURROUNDING SECTION 24, T6N, R2W, SLB&M.

THE BASIS OF BEARING IS THE MONUMENT LINE BETWEEN FOUND MONUMENTS IN 1200 SOUTH STREET AT THE INTERSECTIONS OF 1200 WEST STREET AND 750 WEST STREET WHICH BEARS SOUTH 88°41'21" EAST, UTAH NORTH, STATE PLANE, CALCULATED N.A.D.83 BEARING.

SURVEYOR'S CERTIFICATE

I, MATT PRETL DO HEREBY CERTIFY THAT I AM A REGISTERED PROFESSIONAL LAND SURVEYOR IN THE STATE OF UTAH IN ACCORDANCE WITH TITLE 58, CHAPTER 22, PROFESSIONAL ENGINEERS AND PROFESSIONAL LAND SURVEYORS ACT; AND BY THE AUTHORITY OF THE OWNERS, I HAVE COMPLETED A SURVEY OF THE PROPERTY DESCRIBED AND SHOWN HEREON THIS PLAT IN ACCORDANCE WITH SECTION 17-23-17 AND HAVE VERIFIED ALL MEASUREMENTS, AND THAT THE SAME HAS BEEN SURVEYED AND MONUMENTS HAVE BEEN LOCATED AND/OR PLACED ON THE GROUND AS REPRESENTED ON THE PLAT HEREON.

SIGNED THIS 9TH DAY OF JANUARY, 2026.

MATT PRETL, PLS
 UTAH LAND SURVEYOR LICENSE NO. 10437995

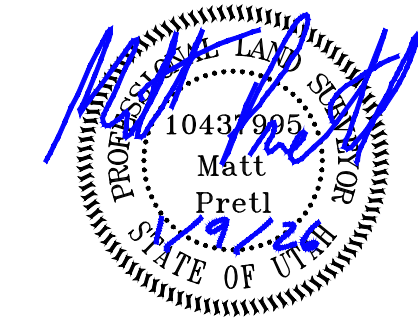

	<p>HANSEN & ASSOCIATES, INC. Consulting Engineers and Land Surveyors 538 North Main Street, Brigham, Utah 84302 Visit us at www.hais.net Logan Ogden (435) 723-3491 (801) 399-4905 (435) 752-8272 Celebrating over 68 Years of Business</p>
<p>Drawn By: MP Date: 1/29/2026 Designed By: _____ Checked By: _____ Approved By: _____ Scale: 1" = 30' Drawing File: 25-3-189v19 JOB NUMBER: 25-3-189</p>	<p>PROPERTY SURVEY FOR FROG PROPERTIES 1278 S 1200 W MARRIOTT SLATERVILLE CITY, WEBER COUNTY, UTAH A PART OF THE NORTHEAST QUARTER OF SECTION 24 TOWNSHIP 6 NORTH, RANGE 2 WEST, S.L.B.&M.</p>
<p>Sheet 1 of 1 Sheets</p>	